

X^{ProTEC}

Sound Level Meter

Operation Manual



XFTP
TRILITHIC



About XProTec Pro-Installer Tools

The XProTec line from XFTP is a comprehensive lineup of professional-grade technical tools. These full-featured, field-proven, and easy-to-use tools meet the highest quality standards in the industry, and feature the dependability you expect for complete installation solutions.

Table of Contents

Safety Instructions & Warnings	3
Care & Handling	3
Environmental Requirements	4
Environment Measurement Requirements	4
Physical Measurement Requirements	4
Measurement Features	5
Functional Overview	6
LCD Display Overview	8
Initial Setup	9
Before Operation	9
Backlight Operation	9
MAX Sound Level Mode Operation	9
Sound Level Hold Mode Operation	9
Measurement Instructions	10
Battery Maintenance	10
Calibration Procedures	11
Specifications	12
Warranty Information	16

Safety Instructions & Warnings



WARNING: Read the following safety information carefully before attempting to operate or service the meter.

Use the meter only as specified in this manual; otherwise, the protection provided by the meter may be impaired.

The meter is protected throughout by double insulation or reinforced insulation. When servicing, use only specified replacement parts. Comply with EMC.

Care & Handling

This unit is a precision instrument which must be handled with care, take note of the following;

- Avoid dust and water, use a soft cloth to clean the unit.
- Avoid shock, vibrations and extreme heat.
- Keep the unit clean and dry.
- Check the battery regularly to avoid deterioration.
- Power off when not in use.
- Remove the battery and store the instrument in a low humidity environment when not in use.
- Repairs or service not covered in this manual should only be performed by qualified service personnel.

Environmental Requirements

The following sections describe the environmental and physical requirements necessary for an accurate measurement.

Environment Measurement Requirements

Temperature and humidity in different environments affect the speed of sound. When accuracy is critical, make sure the sound meter is used in appropriate environment as follows;

- Altitude up to 2000 Meters.
- Maximum Relatively Humidity of 90%.
- Operation Temperature of 0 ~ 40 °C.

Physical Measurement Requirements

To ensure the accuracy of your measurements, please take note of following physical measurement requirements;

- Wind blowing across the microphone will introduce additional extraneous noise. Use the included windscreen to prevent the measurement of undesirable signals.
- To achieve more accurate measurement, use an extension cable to separate the Microphone from the main body so that the effect of unexpected sound reflection can be eliminated.
- Calibrate the instrument before operation if the instrument has not been used for a long period of time or operated in a bad environment.
- Keep microphone dry and avoid severe vibration.

Measurement Features

To ensure that you can obtain the most accurate measurements, we recommend that you read and follow the instructions provided in this Operation Manual carefully before use.

This unit conforms to the IEC651 type 2, ANSI S1.4 type 2 standards for Sound Level Meters.

This Sound Level Meter has been designed to meet the measurement requirements of safety engineers, health, industrial safety offices and sound quality control in various environments.

Measurement ranges are from 30 to 130 dB at frequencies between 31.5 Hz and 8 kHz.

The 4 digit LCD Display shows 0.1 dB measurement steps with two equivalent weighted sound pressure levels A and C.

Functional Overview

The diagram shown below represents the basic controls and features of the Sound Level Meter.

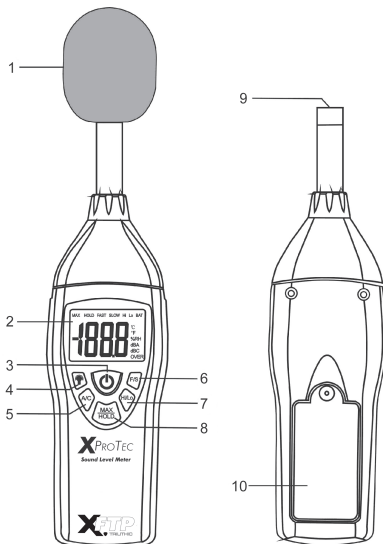

1. **Windscreen**
2. **LCD Display**
3. **POWER** - This button is used to turn the unit ON and OFF.
4. **Backlight** - This button is used to turn the backlight ON and OFF.

5. **A/C** - This button is used to switch the sound weighting between the following;
 - A** - General sound levels.
 - C** - Low-frequency sound levels.If the **C** Weighted measurement level is much higher than the **A** weighted measurement level, then there is a large amount of low-frequency noise.
6. **F/S** - This button is used to switch the time weighting between the following;
 - F** (Fast Response) Used to measure normal sound with fast varying noise.
 - S** (Slow Response) - Used to measure the average sound level of fluctuating noise.
7. **Lo/Hi** - This button is used to switch the sound level between the following;
 - Lo** - Used to measure sound levels between 30 and 100 dB.
 - Hi** - Used to measure sound levels between 60 and 130 dB.Note: During measurement, if the LCD Display shows **OVER** in the **Lo** range the user should switch to the **Hi** Measurement Range.
8. **MAX/HOLD** - This button is used to enter the following modes;
 - MAX** - Used to freeze the LCD Display on the maximum sound level measurement. The maximum sound level measurement is continuously updated.
 - HOLD** - Used to freeze the display on the current value. Hold this button for approximately 2 Seconds to enable.
9. **Microphone** - 1/2 Inch Electret Condenser Microphone.
10. **Battery Cover**

LCD Display Overview

The diagram shown below represents the basic symbols and functions of the Sound Level Meter.

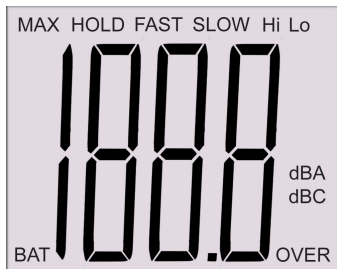

Numeric Digits - 4 Digit Numerical Display with 0.1 dB Resolution

MAX - Maximum Sound Level Mode is Enabled

HOLD - Sound Level Hold Mode is Enabled

FAST or **SLOW** - Fast or Slow Response Time Weighting is Selected

Hi or **Lo** - High (60 to 130 dB) or Low (30 to 100 dB) Sound Level Range is Selected

dBA or **dBC** - A or C Sound Level Weighting is Selected

BAT - Low Battery

OVER - Over Measurement Range

Initial Setup

Before taking any measurement with the Sound Level Meter, perform the actions shown in this section.

Before Operation

To install the new battery, perform the following steps;

1. Remove one (1) screw from the battery cover
2. Remove the battery cover.
3. Connect a standard 9 Volt battery to the unit and replace the cover and screw.

Backlight Operation

Press the **Backlight** Button to activate the LCD Backlight and press the button again to deactivate the LCD Backlight.

MAX Sound Level Mode Operation

When the **MAX** Sound Level Mode is enabled, the meter captures and holds the maximum noise level for a period of time using any: Response Time Weighting, Sound Level Weighting, or Sound Level Range.

Sound Level Hold Mode Operation

When the Sound Level **HOLD** Mode is enabled, the hold function freezes the reading that is shown on the LCD Display. Press and hold the **MAX/HOLD** Button for approximately two (2) seconds to activate or to exit the Sound Level **MAX/HOLD** Mode.

Measurement Instructions

Perform the following steps to take a sound level measurement;

1. Press the **POWER** Button to turn the meter ON.
2. Select the desired Response Time Weighting by pressing the **F/S** Button. If the sound source consists of short bursts or you are trying to capture a peak sound, set the response time to **FAST**. To measure average sound, use the **SLOW** response time setting.
3. Select the desired Sound Level Weighting by pressing the **A/C** Button. If you are trying to capture general noise sound levels, use the **A** Sound Level Weighting. To measure the sound level of acoustic material use the **C** Sound Level Weighting.
4. Select the desired Sound Level Range by pressing the **Hi/Lo** Button.
5. Hold the instrument by hand or affix the meter to a tripod and point the microphone at the noise source.
6. The sound pressure level will be displayed in dB.

Battery Maintenance

When the battery power is not sufficient to operate the unit, the LCD Display will show **BAT** and replacement of the battery is required. To prevent inaccurate measurements, replace the battery as soon as possible.

To replace the battery, perform the following steps;

1. Remove one (1) screw from the battery cover.
2. Remove the battery cover.
3. Disconnect the battery from the unit and replace it with a standard 9 Volt battery and replace the cover and screw.

Calibration Procedures

It is recommended that the Sound Level Meter is calibrated approximately once per year. To calibrate the Sound Level Meter, perform the following steps using a standard Acoustic Calibrator (94 dB, 1 kHz Sine Wave);

1. Press the **F/S** Button to set the Response Time Weighting to **FAST**.
2. Press the **A/C** Button to set the Sound Level Weighting to **dB A**.
3. Press the **Hi/Lo** Button to set the Sound Level range to **Hi** or **Lo**.
4. Disable the **MAX** Sound Level Mode and Sound Level **HOLD** Mode.
5. Insert the microphone housing carefully into the insertion hole of the calibrator.
6. Remove one (1) screw from the battery cover.
7. Pull the battery out of the unit (DO NOT DISCONNECT).
8. Adjust either the A(Hi)-weighting or A(Lo)-weighting potentiometer depending on whether you have chosen the **Hi** or **Lo** Sound Level Range.
9. The LCD Display will show the desired level.

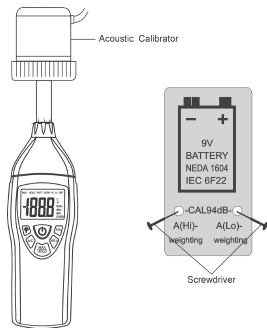

Specifications

Standard Applied: IEC651 type 2, ANSI S1.4 type 2

Frequency Range: 31.5 Hz ~ 8 KHz

Measurement Level Range: 30 ~ 130 dB

Frequency Weighting: A/C

Microphone: 1/2 inch electret condenser microphone

Calibration: Factory calibrated. Can be calibrated with a Standard Acoustic Calibrator (94 dB, 1 kHz sine wave)

Display: LCD

Digital Display: 4 digits

Resolution: 0.1 dB

Response Time: 0.5 Seconds

Time Weighting: FAST (125 mS), SLOW (1 Sec)

Level Ranges:

Lo: 30 - 100 dB

Hi: 60 - 130 dB

Accuracy: ± 1.5 dB (under reference conditions)

Alarm Function: "OVER" is shown when input is out of range

Maximum Hold: Hold the maximum value measurement, with decay < 1dB per 3 minutes

Auto Power Off: Meter automatically shuts down after approximately 15 minutes of inactivity

Power Supply: One 9V battery, 006P or IEC 6F22 or NEDA 1604.

Battery Life: Approximately 50 hours (alkaline battery)

Operation Temperature: 0 - 40 °C (32 - 104 °F)

Operation Humidity: 10 - 90 %RH

Storage Temperature: -10 - 60 °C (14 - 140 °C)

Storage Humidity: 10 - 75 %RH

Dimensions (L x W x H): 210 mm x 55 mm x 32 mm

Weight: 230 g (including battery)



THIS PAGE LEFT INTENTIONALLY BLANK

THIS PAGE LEFT INTENTIONALLY BLANK



Warranty Information

Trilithic, Inc. warrants that each part of this product will be free from defects in materials and workmanship, under normal use, operating conditions and service for a period of one (1) year from date of delivery. Trilithic, Inc.'s obligation under this Warranty shall be limited, at Trilithic, Inc.'s sole option, to replacing the product, or to replacing or repairing any defective part, F.O.B. Indianapolis, Indiana; provided that the Buyer shall give Trilithic, Inc. written notice.

Batteries are not included or covered by this Warranty.

The remedy set forth herein shall be the only remedy available to the Buyer under this Warranty and in no event shall Trilithic, Inc. be liable for incidental or consequential damages for any alleged breach of this Warranty. This Warranty shall not apply to any part of the product which, without fault of Trilithic, Inc., has been subject to alteration, failure caused by a part not supplied by Trilithic, Inc., accident, fire or other casualty, negligence or misuse, or to any cause whatsoever other than as a result of a defect.

Except for the warranty and exclusions set forth above, and the warranties, if any, available to the Buyer from those who supply Trilithic, Inc., there are no warranties, expressed or implied (including without limitation, any implied warranties of merchantability of fitness), with respect to the condition of the product or its suitability for any use intended for it by the Buyer or by the purchaser from the Buyer.



9710 Park Davis Drive
Indianapolis, IN 46235
(317) 895-3600

www.fieldtechproducts.com